

Tru Hone HCA 110V Wiring Diagram Speed Control TH1195 125DV-C

- Adjust **MIN** with Micro Switch or Hi-Low Switch engaged until Honing Wheel Shaft speed = 250 RPM
- Adjust **MAX** with Speed Control Knob at "10" until Honing Wheel Shaft speed = 1500 RPM
- Turn **IR** Clockwise to 10 o'clock
- Turn **CL** Clockwise all the way

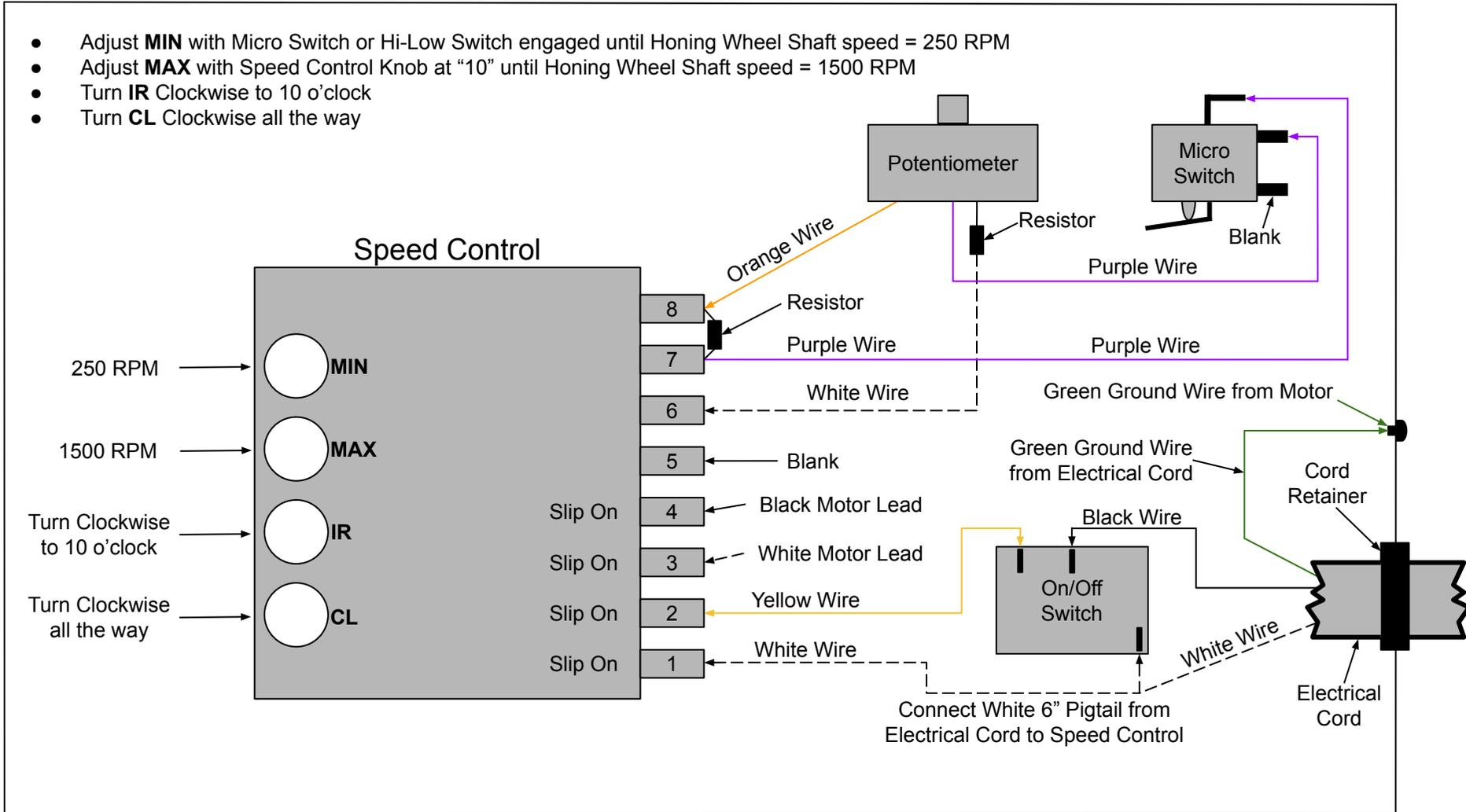

Tru Hone Corporation
1721 NE 19th Avenue
Ocala, FL 34470 USA



800.237.4663
352.622.1213
TruHone.com