

Tru Hone LCF or HCF 220V Wiring Diagram Speed Control TH1194 125DV-C

- Adjust **MIN** with Speed Control Knob at "3" until Honing Wheel Shaft speed = 250 RPM
- Adjust **MAX** with Speed Control Knob at "10" until Honing Wheel Shaft speed LCF = 1450 RPM & HCF = 1500 RPM
- Turn **IR** Clockwise to 10 o'clock
- Turn **CL** Clockwise all the way
- **NOTE:** Press On/Off Switch to On position
turn Speed Control Knob to zero to activate Speed Control

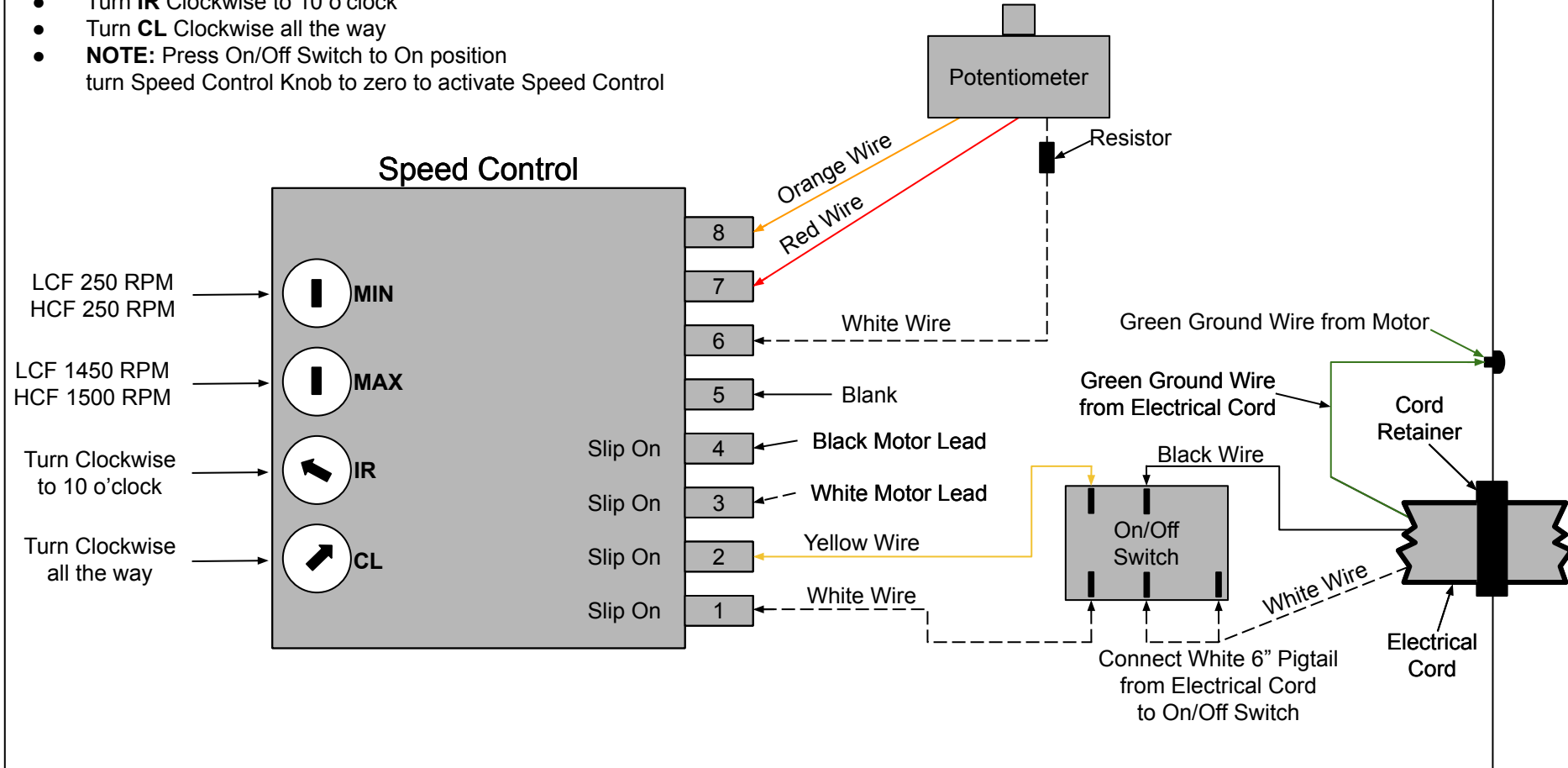

Tru Hone Corporation
1721 NE 19th Avenue
Ocala, FL 34470 USA



800.237.4663
352.622.1213
TruHone.com