

# Tru Hone HCA 110V Wiring Diagram Speed Control TH1192 LGD400

- **Speed Control is factory set**
- If adjustment is necessary, only adjust **MIN SPD**, **MAX SPD** &/or **IR COMP**
- Adjust **MIN SPD** with Micro Switch or Hi-Low Switch engaged until Honing Wheel Shaft speed = 250 RPM
- Adjust **MAX SPD** with Speed Control Knob at "10" until Honing Wheel Shaft speed = 1500 RPM

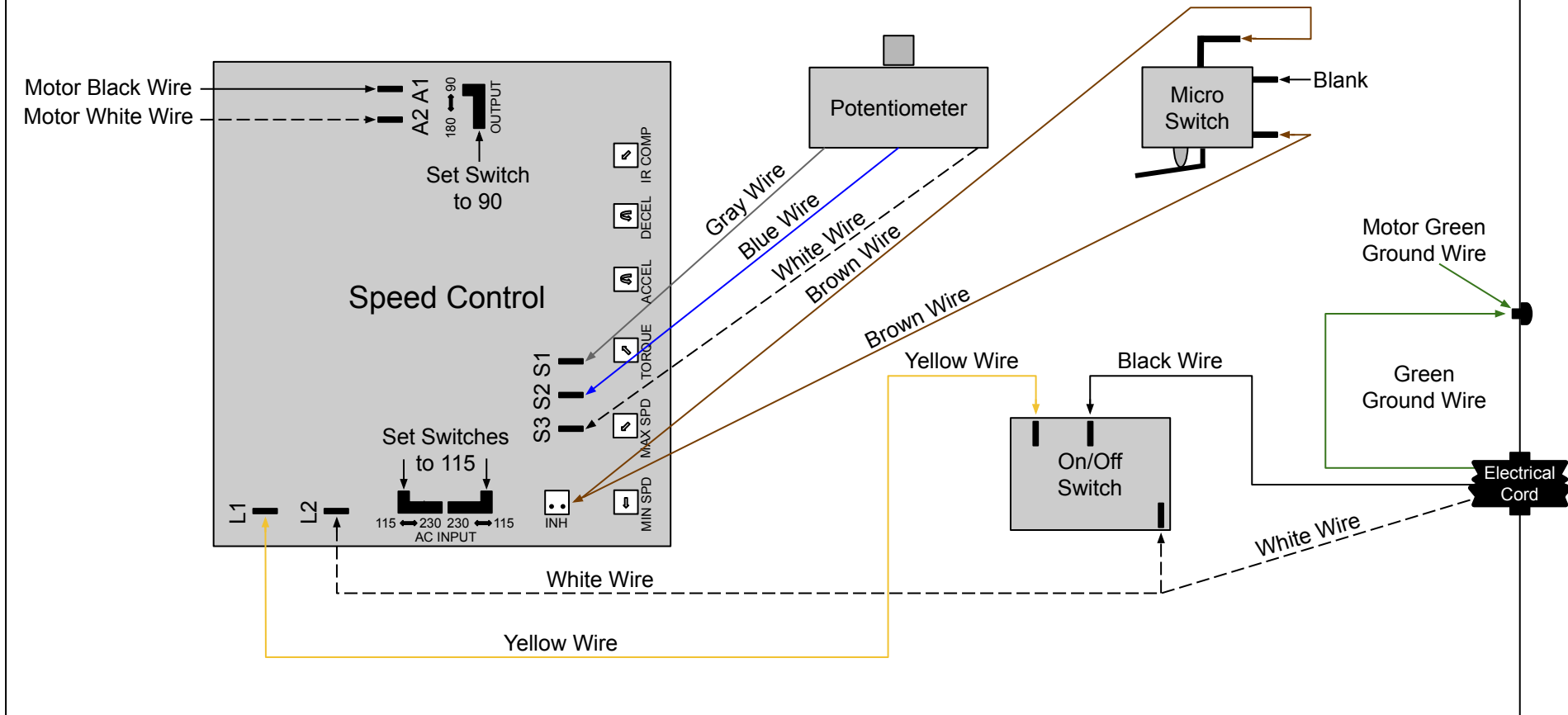

Tru Hone Corporation  
1721 NE 19th Avenue  
Ocala, FL 34470 USA



800.237.4663  
352.622.1213  
TruHone.com