

Tru Hone LCF or HCF 220V Wiring Diagram Speed Control TH1192 LGD400

- **Speed Control is factory set**
- If adjustment is necessary, only adjust **MIN SPD**, **MAX SPD** &/or **IR COMP**
- Adjust **MIN SPD** with Speed Control Knob at "3" until Honing Wheel Shaft speed = 250 RPM
- Adjust **MAX SPD** with Speed Control Knob at "10" until Honing Wheel Shaft speed LCF = 1450 RPM or HCF = 1500 RPM

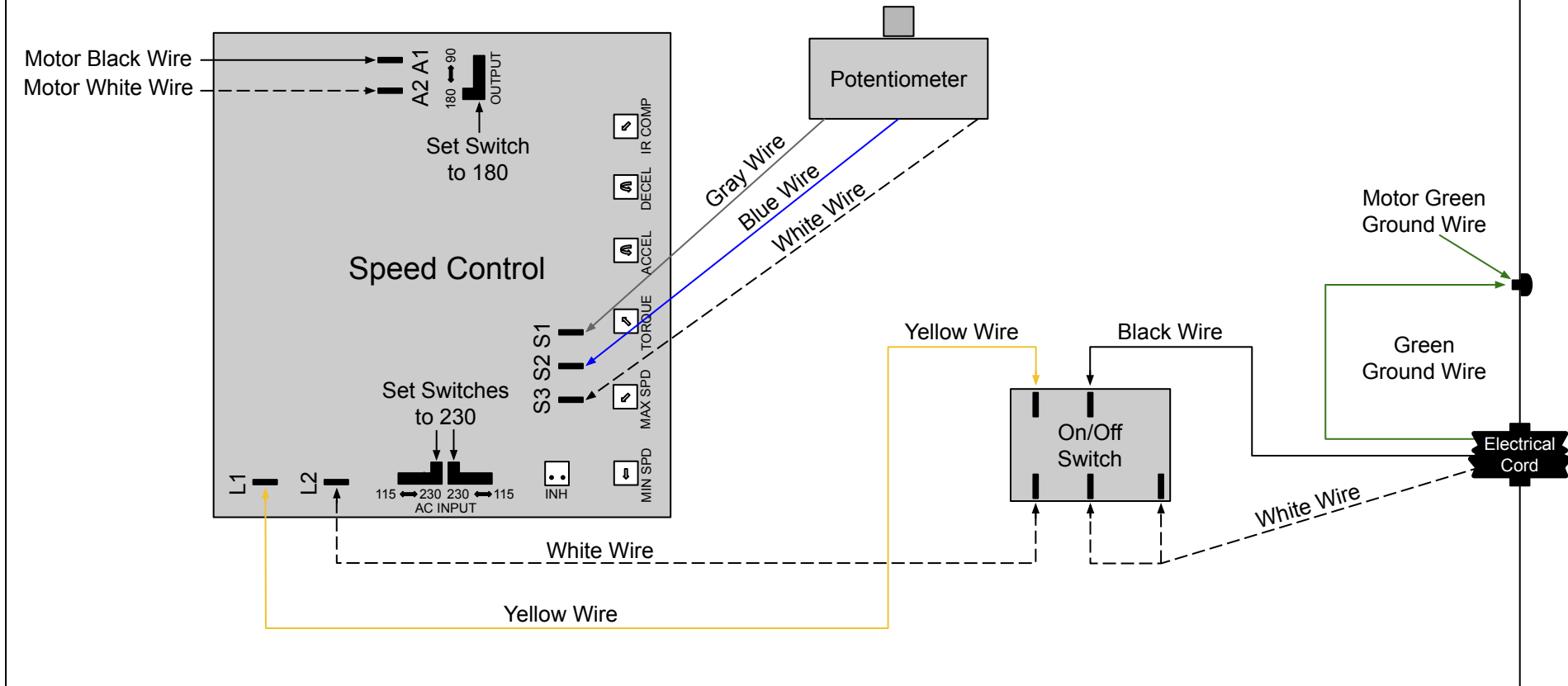

Tru Hone Corporation
1721 NE 19th Avenue
Ocala, FL 34470 USA

TRU HONE
...ends the
"Stone Age"
of Knife Sharpening.

800.237.4663
352.622.1213
TruHone.com